



Automatic Lint Collector

SPECIFICATION

Automatic Lint Collector



Specification of design is subject to change without notice.
For additional options please consult factory and distributor.

MODEL	Units		ALC
Units of Measurement	Metric	US	
Overall Dimensions :			
A-Machine Width	mm.	inch	1093(43)
B-Machine Depth	mm.	inch	1059(41.69)
C-Machine Height	mm.	inch	2647(104.21)
Drive System:			
Blower Motor	kW	HP	7.5 (10)
Power System:			
Power Source	V / Hz / Ph		220 / 380 / 415 V / 50 Hz / 3 Ph 208 – 220 / 440 / 460 V / 60 Hz / 3 Ph
Air System:			
Air connection	mm.		10
Air Flow	cmm.	cfm	184.05(6500)
Ducting Inlet size Ø	mm.	inch	200(7.87)
Ducting Outlet size	mm.	inch	353x259(13.89x10.19)
Air pressure	bar	psi	4-6(58-87)
Air consumption	L/hr.		900
Weight:			
Net Weight (approx.)	kg.	lbs.	650(1433)

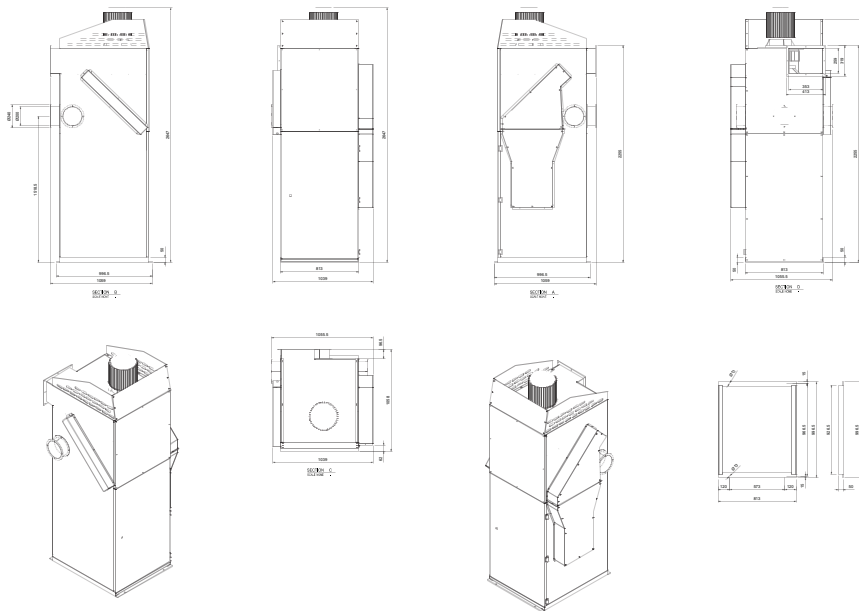

ISO 9001 : 2015



ISO 14001 : 2015



ISO 13485 : 2016



ISO 45001 : 2018



ACCURATE TECHNOLOGIES CO., LTD.

Bangkok, Thailand Phone : +66(0)2740-5511 (Auto) Fax : +66(0)2752-2773

Website : www.imagelaundrysystems.com Email : sales@imagelaundrysystems.com

Rev. 2026-001