



X-Transport

Loading Conveyor

MODEL: XTLC-60

SPECIFICATION

LOADING CONVEYOR

| MODEL | Matric | US | XTLC-60 |
|-----------------------------------|--|---|---|
| Capacity : | | | |
| Compartment Capacity (Dry weight) | kg. | lbs. | 60 (132.2) |
| Number of loading compartments | Compartment | | 4-8 depending on conveyor length and loading capacity |
| Speed : | | | |
| Speed | meter/ min. | | 30 |
| Motor : | | | |
| Water Pump Motor | kW. | | 1.5 |
| Controller | | | |
| Automatic | Integrated with central control system | | |
| Manual | Push button switch | | |
| Power System | | | |
| Voltage | V/ Ph/ Hz | 208-240/ 380-480V/ 50/60Hz/ 3 Ph. + Neutral | |

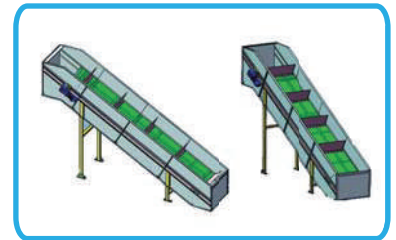

STANDARD FEATURES:

- Motor controlled Three-Phase or Single-Phase
- Loading compartment depending on length and capacity
- Heavy duty construction
- All in contact with linen made of 304 (18/8) stainless Steel
- Belts made of PVC either Black, White or Green color
- Adapted for automatic control
- Manual operation
- Reversing drive

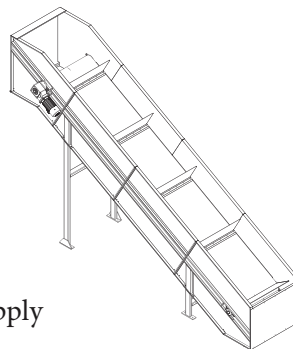
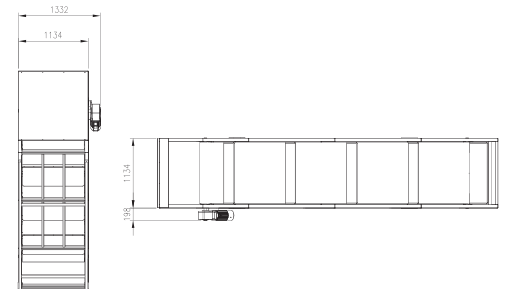
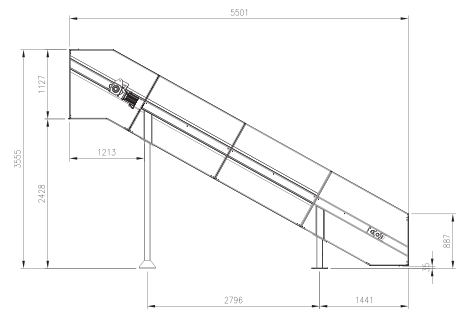

OPTIONAL FEATURES:

- Variable speed with inverter drive
- Automatic weighting system with digital supply



ACCURATE TECHNOLOGIES CO., LTD.

Bangkok, Thailand Phone : +66(0)2740-5511 (Auto) Fax : +66(0)2752-2773

Website : www.imagelaundrysystems.com Email : sales@imagelaundrysystems.com

Rev. 2026-001