



# X-Controller

PC Control Systems,  
PLC Controls, Visualization System

**MODEL: VS1**

# SPECIFICATION

All IMAGE-controls have a proofed long life design the controls are available for;

- Loading conveyors
- Bg loading systems
- Tunnel washer
- Presses
- Shuttle conveyer
- Intermediate conveyer
- Common control units
- Dryer
- Unloading conveyer
- Washer extractors
- Complete washing systems
- Special machineries
- Data record and storage systems



Specification of design is subject to change without notice.  
For additional options please consult factory and distributor.

PLC controls and terminals can handle all different kinds of machineries and systems. PC controls with Touch Screen terminals handle the data input and visualization of all the system processes. High quality built in components guaranty the most effectively.

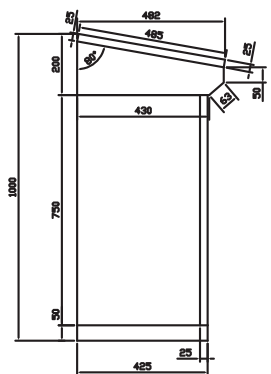
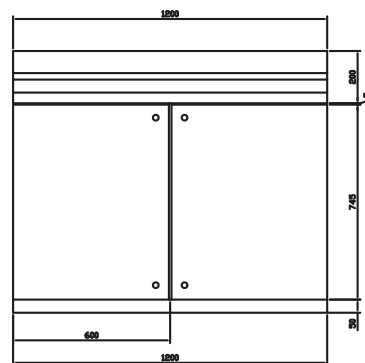
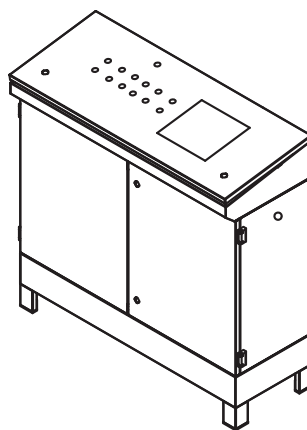
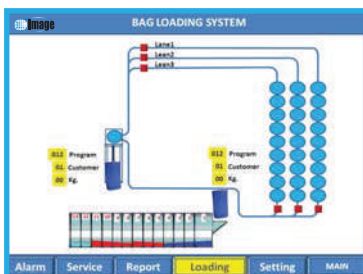
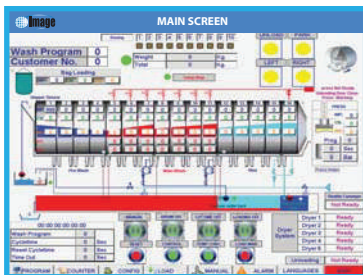
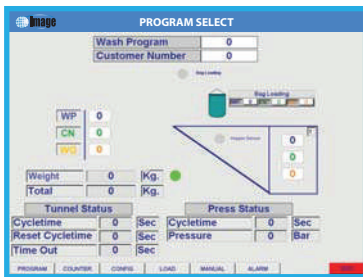

ACCURATE TECHNOLOGIES CO., LTD.

Bangkok, Thailand Phone : +66(0)2740-5511 (Auto) Fax : +66(0)2752-2773  
Website : [www.imagelaundrysystems.com](http://www.imagelaundrysystems.com) Email : [sales@imagelaundrysystems.com](mailto:sales@imagelaundrysystems.com)

Rev. 2026-001