

Amtrans 1&2 Lanes Feeding Machine

High production capacity
Process sheets, duvets, draw sheets and table linen

High quality
1 and 2 lanes operation
Combines quality with high speed

SPECIFICATION

Standard Features :

- Fully automatic operation
- Stretch conveyor
- Open suction box
- Suction under feeding belts
- Automatic speed synchronisation with ironer
- Touch screen control panel
- Up to 100 programs
- Adjustable spreading tension per program
- Inlet-rollers above suction box
- Brushes in suction box
- USB stick connection for backup of settings

Technical Information :

- Electrical
 - Voltage : 3x400 V+N+PE / 50 Hz
 - Power : 3-8 kW, Fuses 16A
- Pneumatic
 - Pressure : 6 - 10 Bar
 - Consumption : 50 KNL/1000 towels
 - Connection : 3/4" (3/4" tube)
- Miscellaneous
 - Noise level : 75 dBA
 - Speed : 8 - 60 m/min
- Production Materials
 - Sheets table linen, draw sheets, etc
 - Max. size : 3.3 m x lane width
 - Min. size : 0.4 m x 0.4 m

Specification of design is subject to change without notice. For additional options please consult factory and distributor.

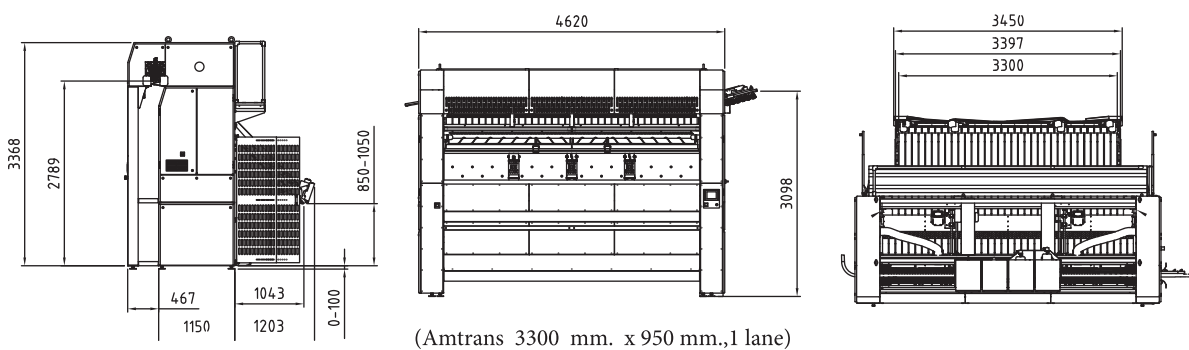

ACCURATE TECHNOLOGIES CO., LTD.

Bangkok, Thailand Phone : +66(0)2740-5511 (Auto) Fax : +66(0)2752-2773
Website : www.imagelaundrysystems.com Email : sales@imagelaundrysystems.com

Rev. 2026-001