



Amfold-B
with **Amstack D**
and Blanket feeder

Blanket folder
2 or 3 Primary folds
Compact
Touch screen panel
All cross folds timing belt driven
Easy access

SPECIFICATION

Optional Features :

- Single lane
- 2 Primary folds (up to 3 primary folds)*
- Up to 3 crossfolds all by knife 1 or 2-lane
- Automatic operational
- Touch screen
- Several cross fold combinations available
- Up to 100 folding programs
- Possibility with several stackers

Standard Features :

- Electrical
 - Voltage : 3x400 V+N+PE / 50 Hz
 - Power : 1.25-2 kW, Fuses 16A
- Pneumatic
 - Pressure : 6 -10 Bar
 - Consumption : 20-30 KNL/1000 sheets
 - Connection : 3/8" (1/2" tube)
- Miscellaneous
 - Noise level : 75 dBA
 - Speed : 25 m/min
- Production Materials
 - Blankets (with crossfolds)
 - Max. size 1 lane : 3.3 m x working width
 - Min. size 1 lane : 0.9 m x 0.9 m
 - Small pieces
 - Max. size multilane : 1.3 m x lane width
 - Min. size multilane : 0.4 m x 0.25 m

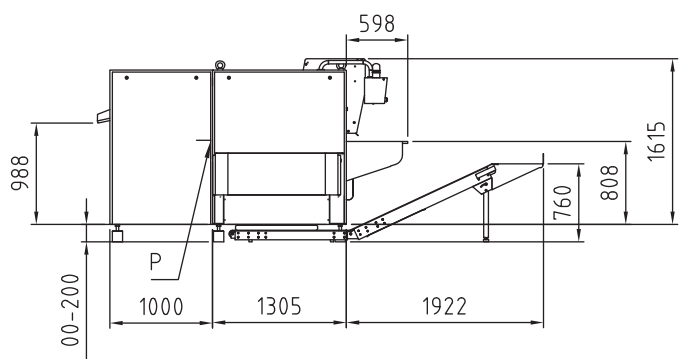
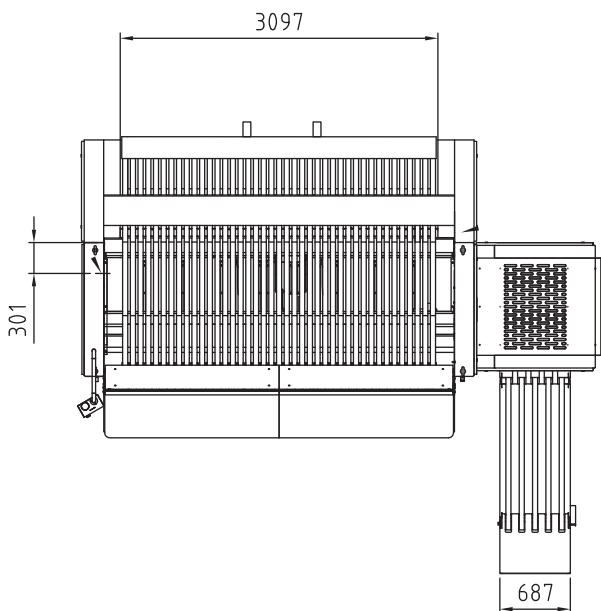
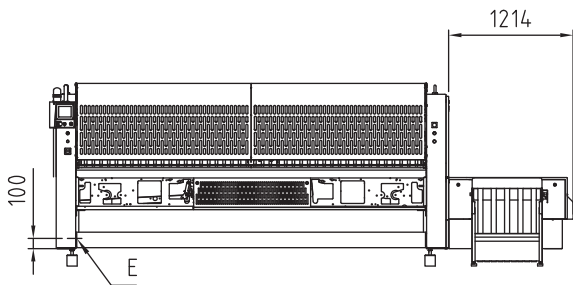

(Amfold-B Amstack-D/Left)

Specification of design is subject to change without notice. For additional options please consult factory and distributor.



ACCURATE TECHNOLOGIES CO., LTD.

Bangkok, Thailand Phone : +66(0)2740-5511 (Auto) Fax : +66(0)2752-2773

Website : www.imagelaundrysystems.com Email : sales@imagelaundrysystems.com

Rev. 2026-001