



Amfold-P
with **Amstack D**
(Amscan is optional)

Standard sheet folder,
all crossfolds with knife folds

SPECIFICATION

Standard Features : Amfold-P

- Single lane or multiple lanes
- 2 Primary folds
- Up to 3 cross folds
- Automatic operation
- Program control from Feeder
- Able to connect with any Ironer
- Photocells face down without mirror
- Several cross fold combinations available
- PLC touch screen
 - Pneumatic folding
 - Standard Ethernet connection
 - Programmable for different types of linen
 - Counting linen in each lane, linen folds per day
 - USB stick connection for backing up of settings

Standard Features : Amstack-D

- Voltage 380 v / 50 Hz / 3 Ph
- Programmable pieces stacked from 1-18 pieces
- Microprocessor control to work as a single unit with Folder
- Attach to a Folder at either end and synchronize with a Folder

Technical Information :

- Electrical
 - Voltage : 3x380 V+N+PE / 50 Hz
 - Power : 1.25-2 kW, Fuses 10A
- Pneumatic
 - Pressure : 6 -10 Bar
 - Consumption : 20-30 KNL/1000 sheets
 - Connection : 3/8" (1/2" tube)
- Miscellaneous
 - Noise level : 75 dBA
 - Speed : 8 up to 50 m/min
- Production Materials
 - Sheets (with crossfolds)
 - Sheets, table linen, draw sheets, etc.
 - Max. size 1 lane : 3.0 m x 3.0 m
 - Min. size 1 lane : 0.9 m x 0.9 m
 - Small pieces
 - Max. size multilane : 1.3 m x lane width
 - Min. size multilane : 0.4 m x 0.25 m

Specification of design is subject to change without notice. For additional options please consult factory and distributor.

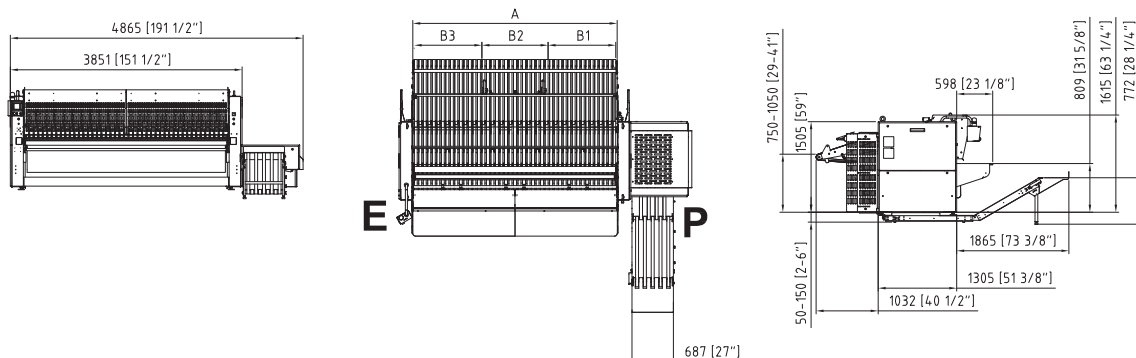

ACCURATE TECHNOLOGIES CO., LTD.

Bangkok, Thailand Phone : +66(0)2740-5511 (Auto) Fax : +66(0)2752-2773
 Website : www.imagelaundrysystems.com Email : sales@imagelaundrysystems.com

Rev. 2026-001