



Amfeed- S

MANUAL FEEDER

Manual feeder
Ergonomic small piece feeding

SPECIFICATION

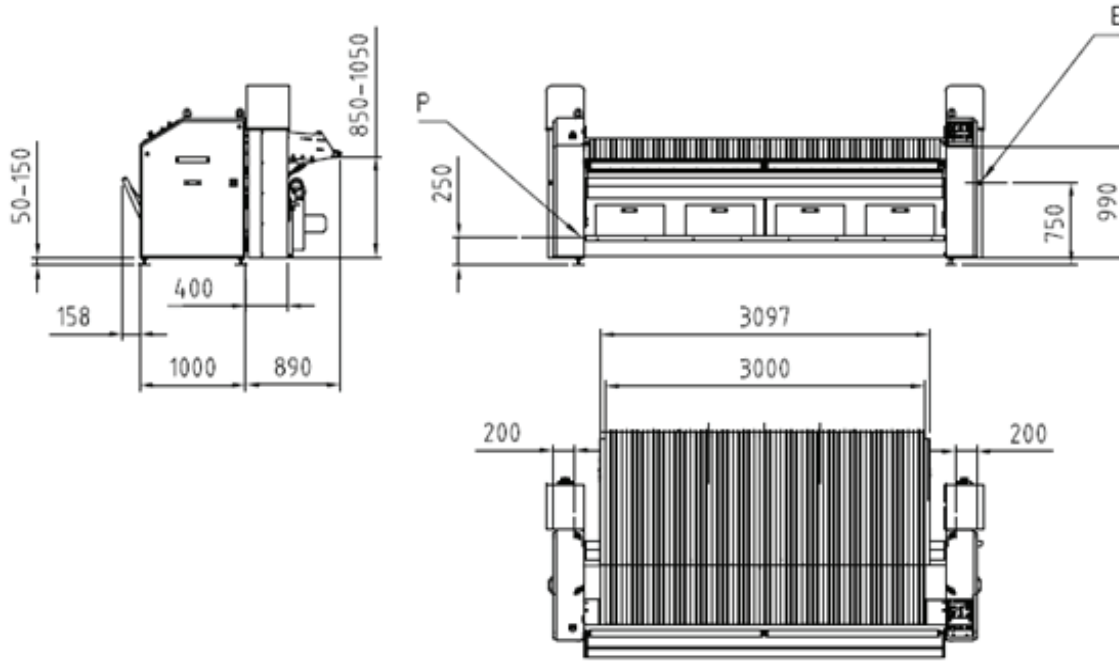

Technical Information :

- Electrical
 - Voltage : 3x400 V+N+PE / 50 Hz
 - Power : 3 kW, Fuses 10A*
- Pneumatic
 - Pressure : 6 - 10 Bar
 - Consumption : 1000 NL/1000 towels
 - Connection : 3/8" (1/2" tube)
- Miscellaneous
 - Noise level : 75 dBA
 - Speed : 8 - 40 m/min
- Production Materials Sheets
 - Sheets, table linen, draw sheets, etc.
 - Max. size : 3.3 m x working width
 - Min. size : 0.4 m x 0.4 m
- Small pieces
 - Max. size : 3.3 m x lane width
 - Min. size : 0.4 m x 0.4 m

Standard Features :

- Suction under feeding belts
- Multilane small piece feeding
- Automatic speed synchronisation with ironer
- Inlet-rollers above suction box
- Dust collection
- Bag for small pieces
- Adjustable vacuum



ACCURATE TECHNOLOGIES CO., LTD.

Bangkok, Thailand Phone : +66(0)2740-5511 (Auto) Fax : +66(0)2752-2773
 Website : www.imagelaundrysystems.com Email : sales@imagelaundrysystems.com

Rev. 2026-001