

SPECIFICATION



Standard Features :

- All wetted parts are 304 (18/8) stainless steel
- 3 or 4 compartments supply dispensers
- 30-cycle microprocessor
- 150G extraction force
- 5 degree lean back for strength and easier loading
- Built in vacuum breaker
- Variable speed frequency inverter

Optional Features :

- Direct Steam Heating
- Electrical Heating
- EMI Filter for CE
- Special Voltage Modifications

Model			HE-20	HE-30	HE-40	HE-60	HE-80	HE-100
Units of Measurement	Metric	US						
Maximum Capacity	kg.	lbs.	9.1 (20)	13.6 (30)	18.1 (40)	27.2 (60)	36.3 (80)	45.4 (100)
Overall Dimensions :								
A - Machine Width	mm.	inch	663 (26.1")	735 (28.9")	785 (30.9")	880 (34.6")	1050 (41.3")	1050 (41.3")
B - Machine Depth	mm.	inch	807 (31.8")	946 (37.2")	1135 (44.7")	1201 (47.3")	1247 (49.1")	1388 (54.6")
C - Machine Height	mm.	inch	1201 (47.3")	1290 (50.8")	1335 (52.6")	1469 (57.8")	1716 (67.6")	1723 (67.8")
Cylinder Information :								
Basket Diameter	mm.	inch	524 (20.6")	610 (24.0")	680 (26.8")	790 (31.1")	920 (36.2")	920 (36.2")
Basket Depth	mm.	inch	350 (13.8")	435 (17.1")	490 (19.3")	560 (22.0")	540 (21.3")	680 (26.8")
Basket Volume	cu.m	cu.ft	0.08 (3)	0.13 (5)	0.18 (6)	0.27 (10)	0.36 (13)	0.45 (16)
Door Opening and Height :								
Door opening Diameter	mm.	inch	365 (14.4")	365 (14.4")	365 (14.4")	450 (17.7")	510 (20.1")	510 (20.1")
Height of Door Bottom Above Floor	mm.	inch	387 (15.2")	445 (17.5")	465 (18.3")	540 (21.3")	610 (24")	627 (24.7")
Drive Information :								
Number of Motors	Number		1	1	1	1	1	1
Size of Motor	kW	HP	0.75 (1)	1.5 (2)	2.2 (3)	3.7 (5)	5.5 (7.5)	7.5 (10)
Cylinder Speeds :								
Wash	RPM	G-Force	48.5 (0.8)	48.5 (0.8)	44.4 (0.8)	43 (0.8)	39.5 (0.8)	39.5 (0.8)
Distribution	RPM	G-Force	76.5 (2)	77 (2)	70.2 (2)	67 (2)	62 (2)	62 (2)
Extract	RPM	G-Force	484 (80)	664 (150)	608 (150)	583 (150)	540 (150)	540 (150)
Water Inlets and Consumption :								
Hot Water Size	NPT		3/4"	3/4"	3/4"	3/4"	3/4"	1"
Cold Water Size	NPT		3/4"	3/4"	3/4"	3/4"	3/4"	1"
Additional Water Inlet	NPT		3/4"	3/4"	3/4"	3/4"	3/4"	1"
Average HOT Water Consumption/Cycle	liters	gal	22 (6)	22 (6)	23 (6)	46 (12)	48 (13)	58 (15)
Average COLD Water Consumption/Cycle	liters	gal	67 (18)	67 (18)	69 (18)	104 (27)	137 (36)	168 (44)
Drain Outlets and Capacity :								
Number of Drains	Number		1	1	1	1	1	1
Drain Size	mm.	inch	50.8 (2")	50.8 (2")	50.8 (2")	76.2 (3")	76.2 (3")	76.2 (3")
Drain Capacity	liters/min	gpm	117 (31)	117 (31)	310 (81.9)	581 (153.5)	581 (153.5)	581 (153.5)
Steam Inlet and Consumption :								
Steam Inlet Connection	NPT		1/2"	1/2"	1/2"	1/2"	1/2"	1/2"
Steam Pressure	bar	Psi	6 (100)	6 (100)	6 (100)	6 (100)	6 (100)	6 (100)
Steam Consumption	kg/hr	lb/hr	11 (24.15)	11 (24.15)	23.5 (51.75)	34.4 (75.9)	56.3 (124.2)	56.3 (124.2)
Weight and Shipping Information :								
Net Weight (approx.)	kg.	lbs.	240 (530)	286 (630.5)	437 (963.4)	499 (1100)	740 (1631)	875 (1930)
Domestic Shipping weight (approx.)	kg.	lbs.	286 (630.5)	302 (665.8)	455 (1003)	519 (1144)	767 (1691)	895 (1973)

** The technical data listed above are based on standard features only. To get information for optional features please contact factory and distributor. Specification of design is subject to change without notice. For additional options please consult factory and distributor.

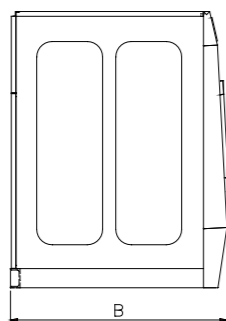
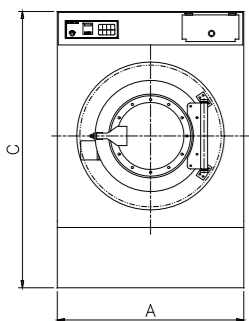

ISO 9001 : 2015

ISO 14001 : 2015



ISO 13485 : 2016



ISO 45001 : 2018



ISO 9001 : 2015



Washer Extractor

HE Series

MODEL : HE-20, HE-30, HE-40,
HE-60, HE-80, HE-100



HE Series - HARDMOUNT

The Image HE series - Hardmount Medium Speed Economy Washer- Extractors for General Laundry Applications

Medium Speed Economy Washer - Extractors

Outstanding Reliability and Efficiency at a Price you can afford

Powerful, efficient, and affordable. These are the design keys for the economy series of Hardmount washer-extractors. Our simple innovative features and robust design ensure low cost of ownership and infrequent maintenance. Simple design and fewer parts are the guarantee. Our combined engineering expertise in the industry assures that you will receive the best for less and products that will meet today's and tomorrow's need in the laundry industry. We know you don't have time to deal with breakdowns.

Advanced Touch Screen Control

The IMAGE Touch Screen Controller (IWT) is an advanced and user-friendly system capable of storing up to 50 customizable wash programs. Featuring an intuitive GUI interface, multi-language support, and USB & SD card connectivity, it enables easy program management via IWS software. The controller precisely manages water levels, temperature, wash speeds, drainage, and chemical dosing to deliver optimum wash performance with maximum efficiency and lower operating costs.



Large Door Opening and Safe Door Interlock

Loading and unloading are fast and easy through the oversized door that opens 180 degrees. The door is located at a convenient height and is constructed of stainless steel and built with an oversize stainless steel hinge for extra strength and durability. The silicon door gasket is designed for long life and seals to the shell every time without leaking. A powerful and safe electro-mechanical door interlocking system is provided for safe and easy operation.



Supply Dispenser

A 3 or 4 compartment dispenser is standard. It is mounted in the front of the machine at a convenient height for easy reach and flushes automatically. The location of the dispenser allows machines to be placed next to each other. As standard the HE model machines are provided with four supply signals and four connections for external liquid supply.



Solid Bearing Housing with High Quality Bearings and Seals

Rugged cast iron construction is used in our durable bearing housing. The shaft is constructed of high strength steel. Oversized permanently lubricated ball bearings are service free and designed for extended life. Double lip seals and a face seal protect the bearings. A large leak off area is provided, which yields long bearing life.

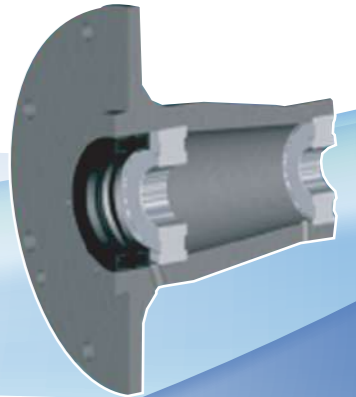

Robust Energy Efficient Drive

The machine is provided with a single totally enclosed standard motor that is controlled electronically by a variable frequency drive. This makes the machine control simple and very flexible. The inverter reduces the peak energy demand, saving energy and lowers the inrush current. It is also a watchdog for the motor, protecting against overload and over voltage. The single motor drive and inverter eliminate clutches, gear reducers, idlers, plus reduces the use of electromechanical components such as contactors and relays. It provides a powerful yet simple drive alternative that is more economical than multi motor drives. The inverter makes it possible to achieve high extract speeds that achieve significant energy and time saving in the drying process.



Solid Mount Construction

Amazing strength and fewer parts give the HE series extra long life, without needless breakdowns. The frame is engineered, computer analyzed, and tested for a lifetime rigorous operation. It has a protective powder coating to reduce possible corrosion and prolong the life.

