



X-Controller

PC Control Systems,
PLC Controls, Visualization System

MODEL: VS1

SPECIFICATION

All IMAGE-controls have a proofed long life design the controls are available for;

- Loading conveyors
- Bg loading systems
- Tunnel washer
- Presses
- Shuttle conveyor
- Intermediate conveyor
- Common control units
- Dryer
- Unloading conveyor
- Washer extractors
- Complete washing systems
- Special machineries
- Data record and storage systems



Specification of design is subject to change without notice. For additional options please consult factory and distributor.

PLC controls and terminals can handle all different kinds of machineries and systems. PC controls with Touch Screen terminals handle the data input and visualization of all the system processes. High quality built in components guaranty the most effectively.

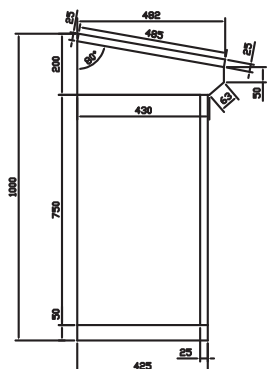
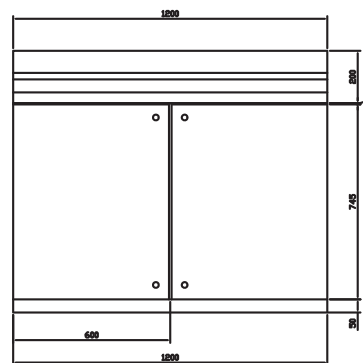
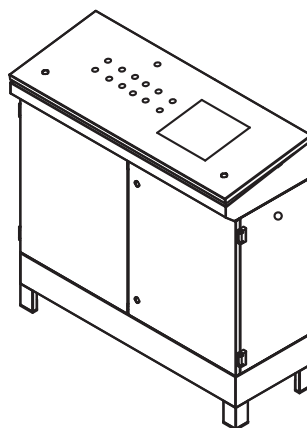
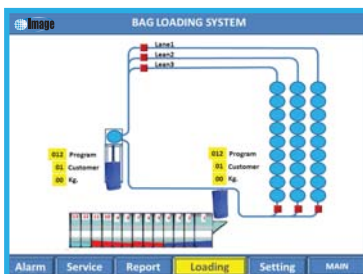
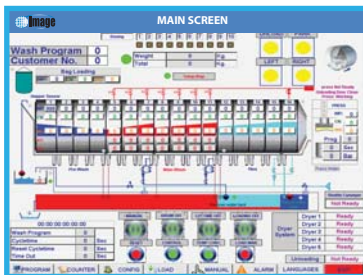
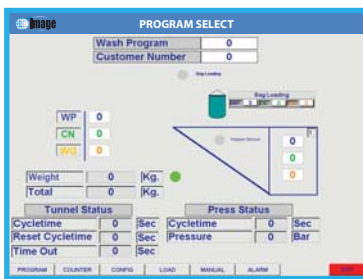

UKRS is a member of Registrar of Standards (Holdings) Ltd
ISO 9001 : 2015



UKRS is a member of Registrar of Standards (Holdings) Ltd
ISO 14001 : 2015



ISO 13485 : 2016

ACCURATE TECHNOLOGIES CO., LTD.

Bangkok, Thailand Phone : +66(0)2740-5511 (Auto) Fax : +66(0)2752-2773
Website : www.imagelaundrysystems.com Email : sales@accuratethai.com

Rev. 2019-000